

Double & King Size

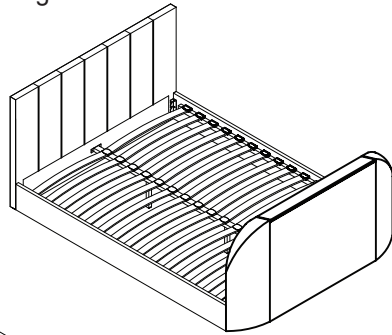

Super King Size

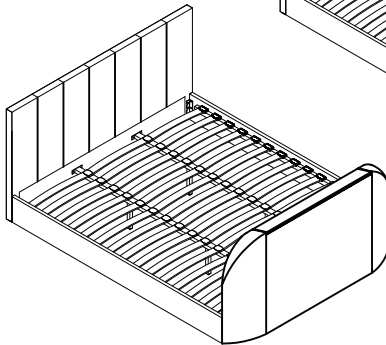

PLEASE READ this sheet prior to assembly to familiarise yourself with the various stages of construction. Carefully open the pack supplied and check the contents against the parts and fittings check list.

Do not destroy any of the packaging until you are certain that you have all the necessary parts for the assembly.

Please ensure that the packaging is disposed of in a safe environmentally friendly way.

CAUTION: There are small components used in the construction of this unit. These loose items should be kept away from young children during assembly, to avoid the danger of choking.

IMPORTANT: BEFORE STARTING TO ASSEMBLE THE BED - PLEASE READ THESE INSTRUCTIONS CAREFULLY.

Parts Identification

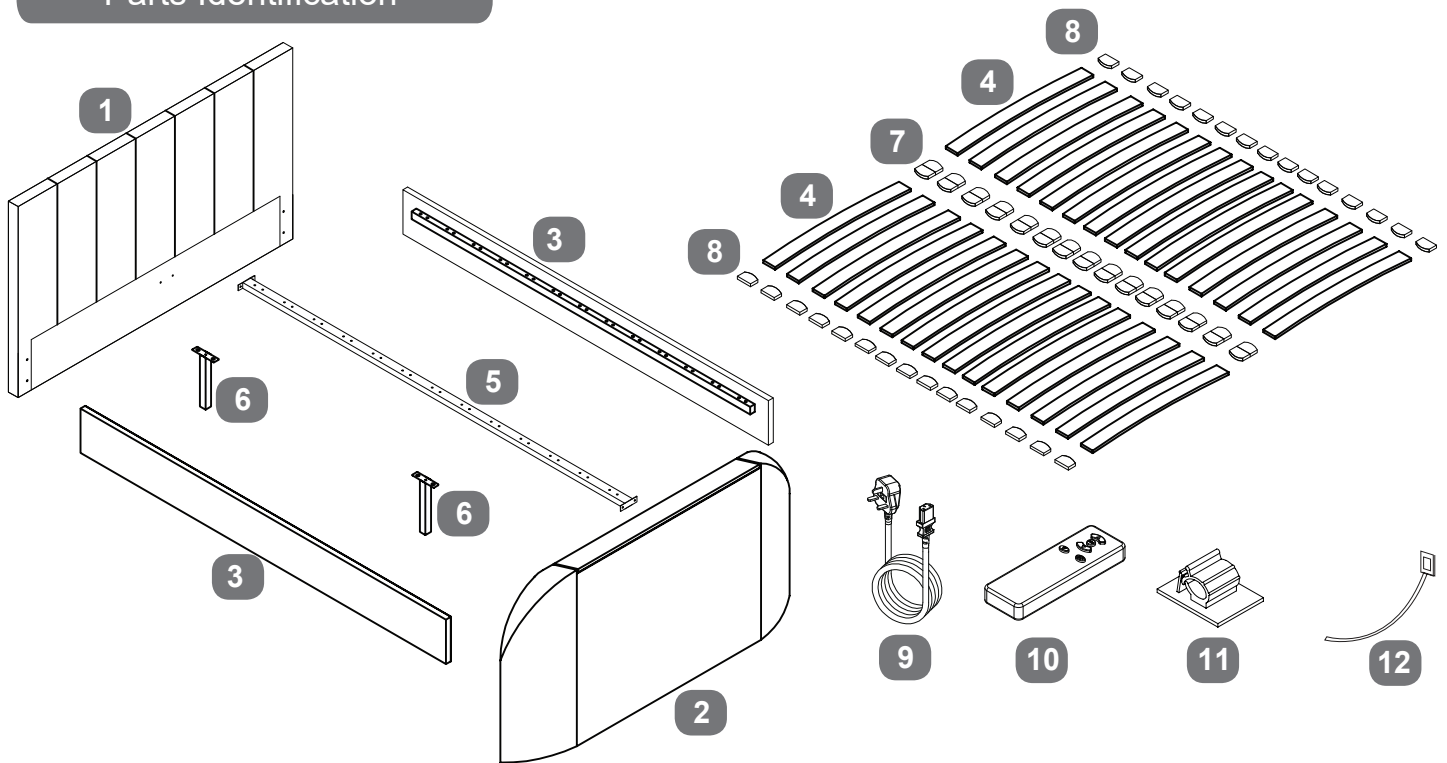

Parts Checklist

Ref.	Description	Qty	Box	Ref.	Description	Qty	Box
1	Headboard	1	1	7	Double Slat Caps <small>Double / King / Super King</small>	14/15/30	2
2	Footboard	1	2	8	Single Slat Caps <small>Double / King & Super King</small>	28/30	2
3	Side Rails	2	3	9	Mains Power Lead - 3mt	1	2
4	Wooden Slats	<small>Double / King / Super King</small> 28/30/45	3	10	Remote Control for TV Lift	1	2
5	Centre Support Bar	<small>Double & King / Super King</small> 1/2	3	11	Cable Clips	3	2
6	Legs for Centre Support	<small>Double & King / Super King</small> 2/4	2	12	Cable Ties	3	2

Fittings Checklist

HARDWARE NEEDED FOR BED ASSEMBLY (PACK A)

Ref.	Description	Qty	Ref.	Description	Qty
A	Bolts (M8x25mm)	Double & King x32 Super King x40	D	Allen key for M8 Bolts	x1
B	Spring Washer for M8 bolts	Double & King x32 Super King x40	Ea	Hook Bracket	x2
C	Flat Washer for M8 bolts	Double & King x32 Super King x40	Eb	Hook Bracket	x2

IF BOLTS ARE SUPPLIED WITH YOUR TV, USE THOSE IN PREFERENCE

TV INSTALLATION KIT - Inside Hardware pack (B) Choose a suitable sets of bolts & Allen key

a	Counter-Sunk Screws (M4x12mm)	x2	b	Allen Key (2.5mm)	x1
	Counter-Sunk Screws (M6x12mm)	x2		Allen Key (4mm)	x1
	Screw-Washer sets (M8x25mm) - Use 5mm Allen Key (D)	x2			

Additional Tools Required

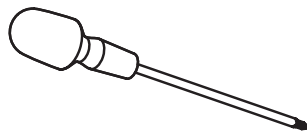

Cross-head Screwdriver

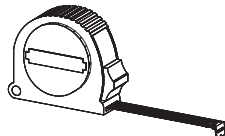

Tape Measure



Please retain your assembly instruction and tools provided for future use. Periodically check that all bolts are still tight.

Care & Maintenance

In the unlikely event of missing or damaged parts, please contact your retailer. Please have this guide at hand quoting the part code reference numbers shown when requesting spare or replacement parts.









2 1/2 Hrs

Approximate time to assemble this product

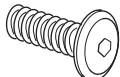
		Press once and TV will rise to it's upper working position. Power to the TV will be connected automatically
		Press once and TV Lift will stop.
		Press once and TV will go down - as soon as the lower resting position is reached power to the TV is switched off to prevent it overheating.
		Torch
		Code Matching
	<p>Code Matching (pairing): occasionally pairing is lost, perhaps due to atmospheric conditions, To re-pair - press and hold the code matching button whilst connecting the power by plugging the mains cable into the control box of the TV lift on the base of the footboard. Continue to press the button for another 5 seconds then press the up or down button to successfully match the code.</p> <p>Regularly check the batteries and if necessary re-place them - x3 pcs AAA size.</p>	



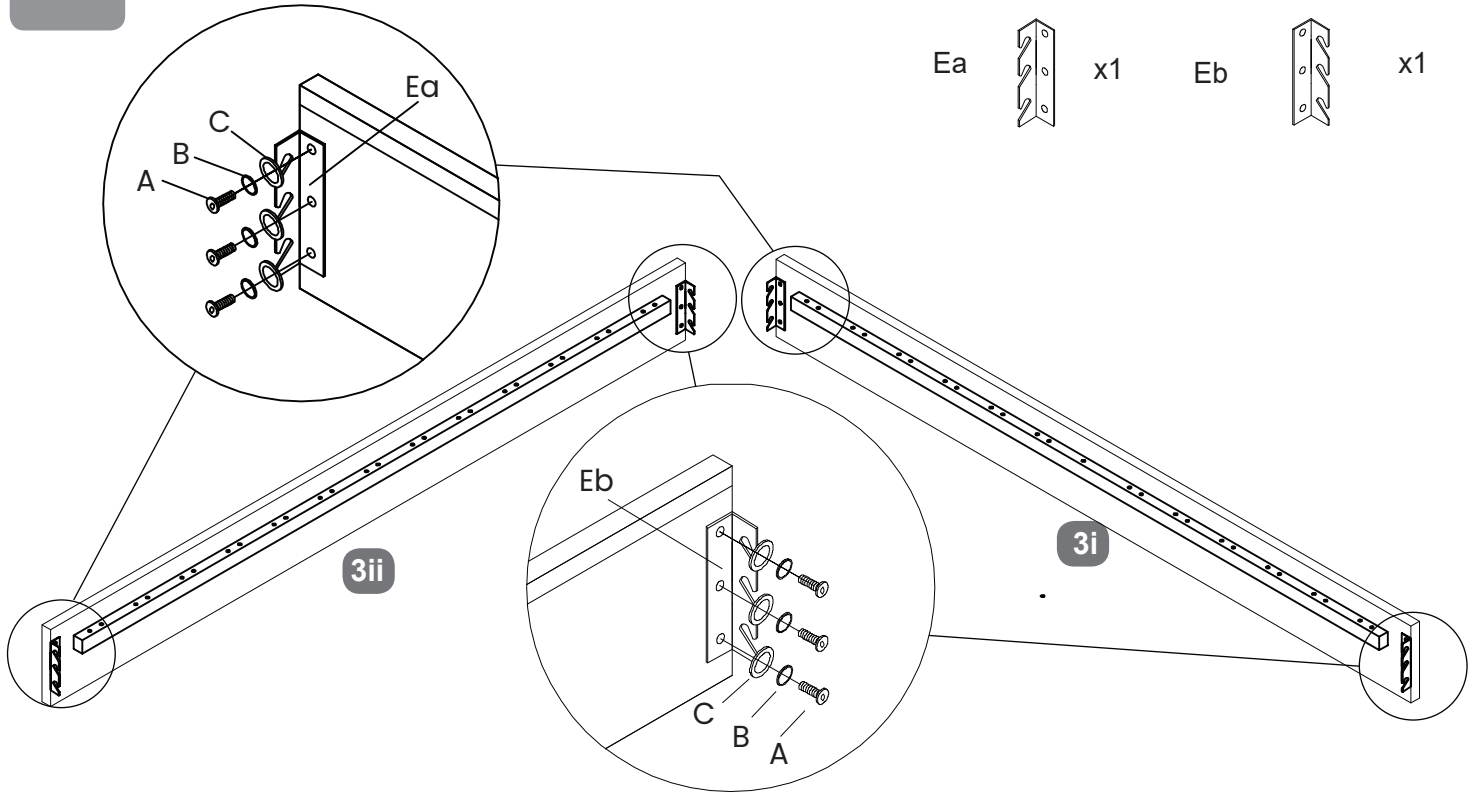

Bed Assembly

Stage
1

- A  x12
- B  x12
- C  x12
- D  x1
- Ea  x1
- Eb  x1

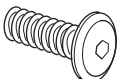

Stage
2

- A  x12
- B  x12
- C  x12
- D  x1

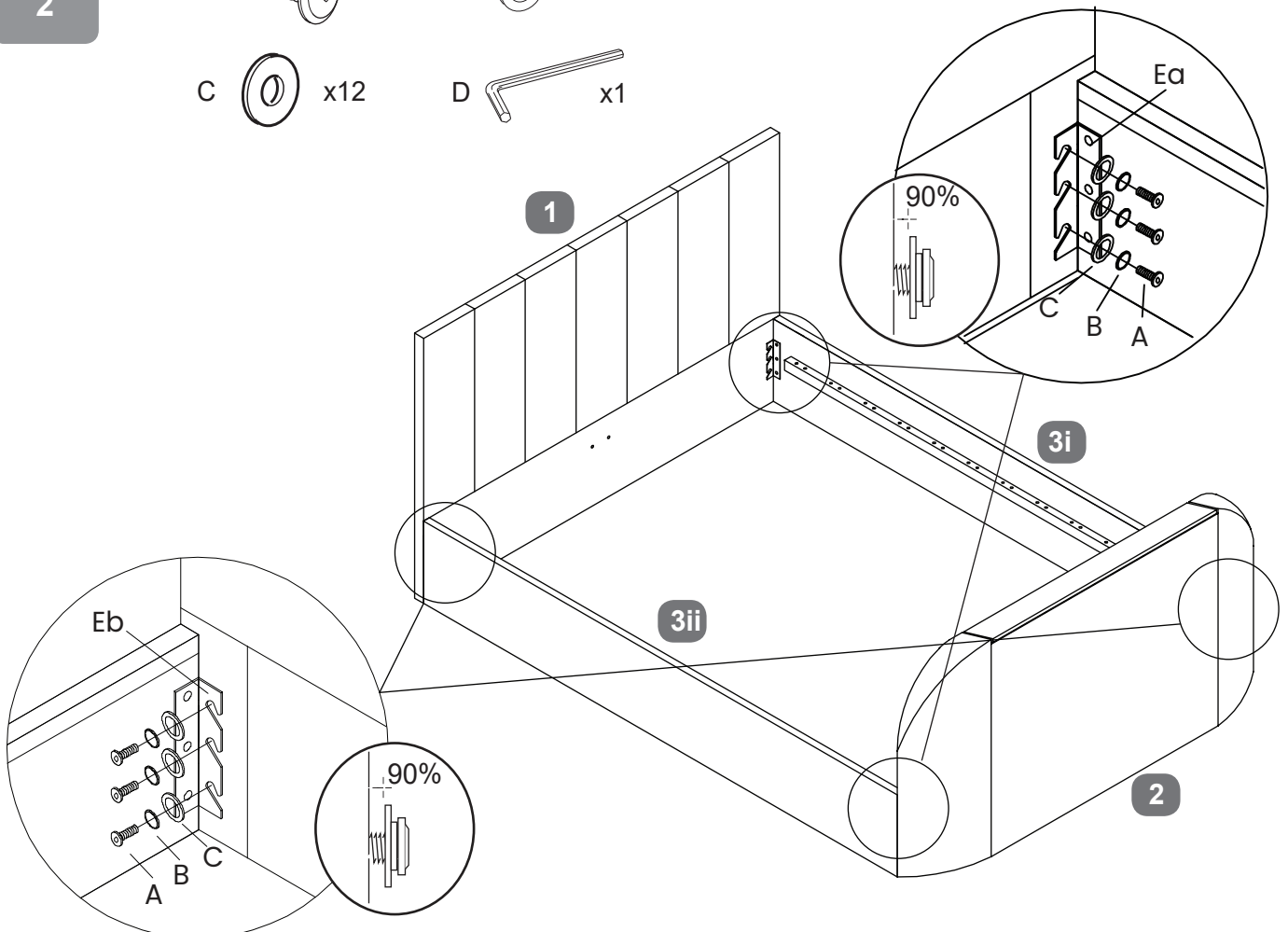

Stage
3

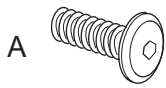

Double & King x8
Super King x16



Double & King x8
Super King x16



Double & King x8
Super King x16



x1

Double & King x2
Super King x4

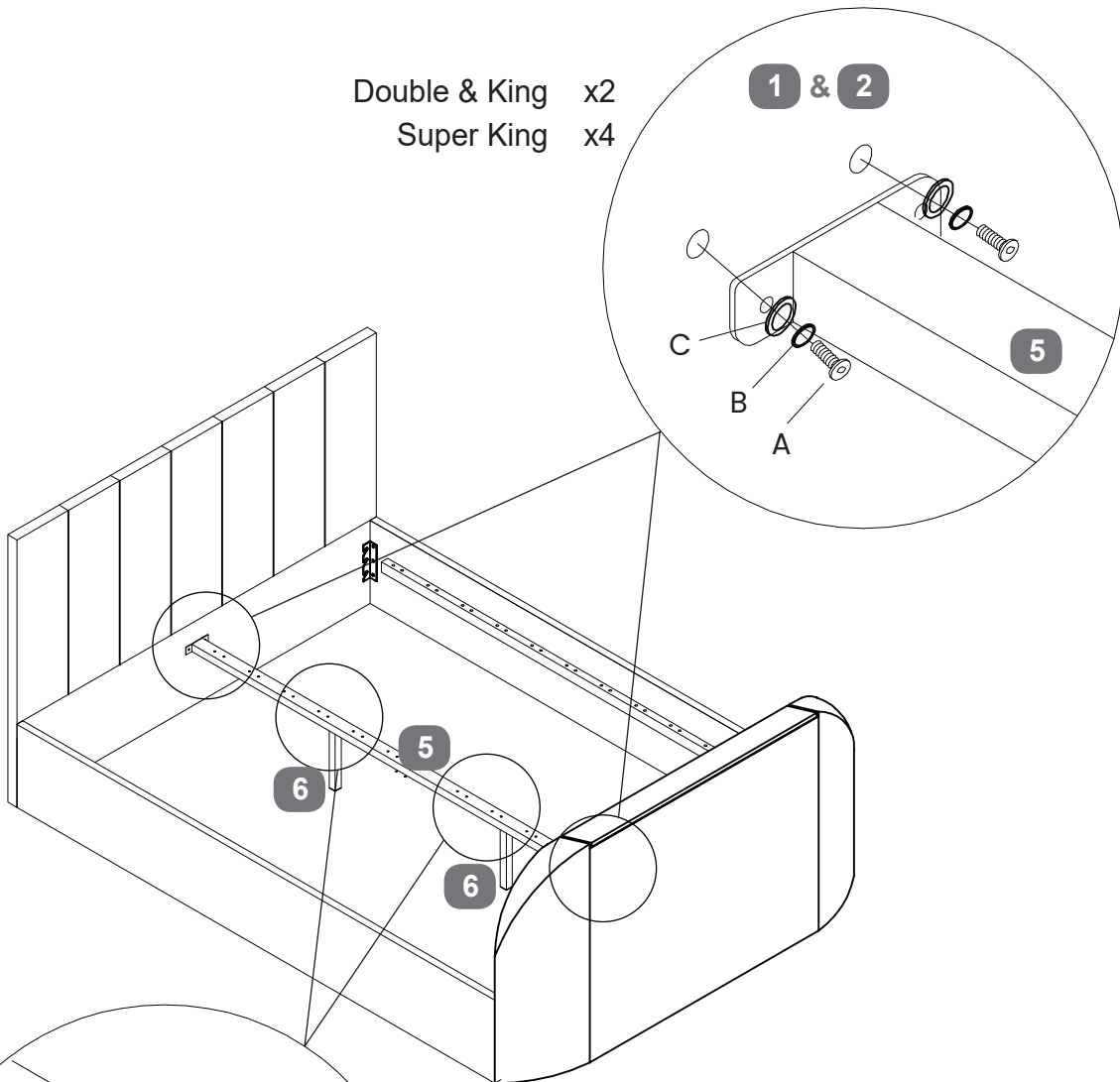

Double & King x2
Super King x4

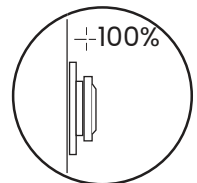
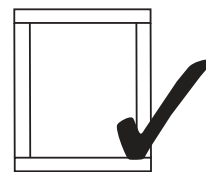
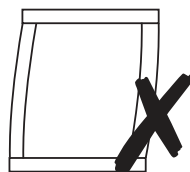
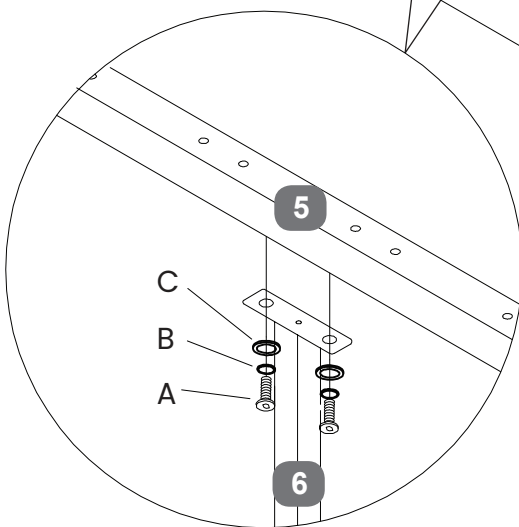

Electrical & Cable Connections

Stage

4

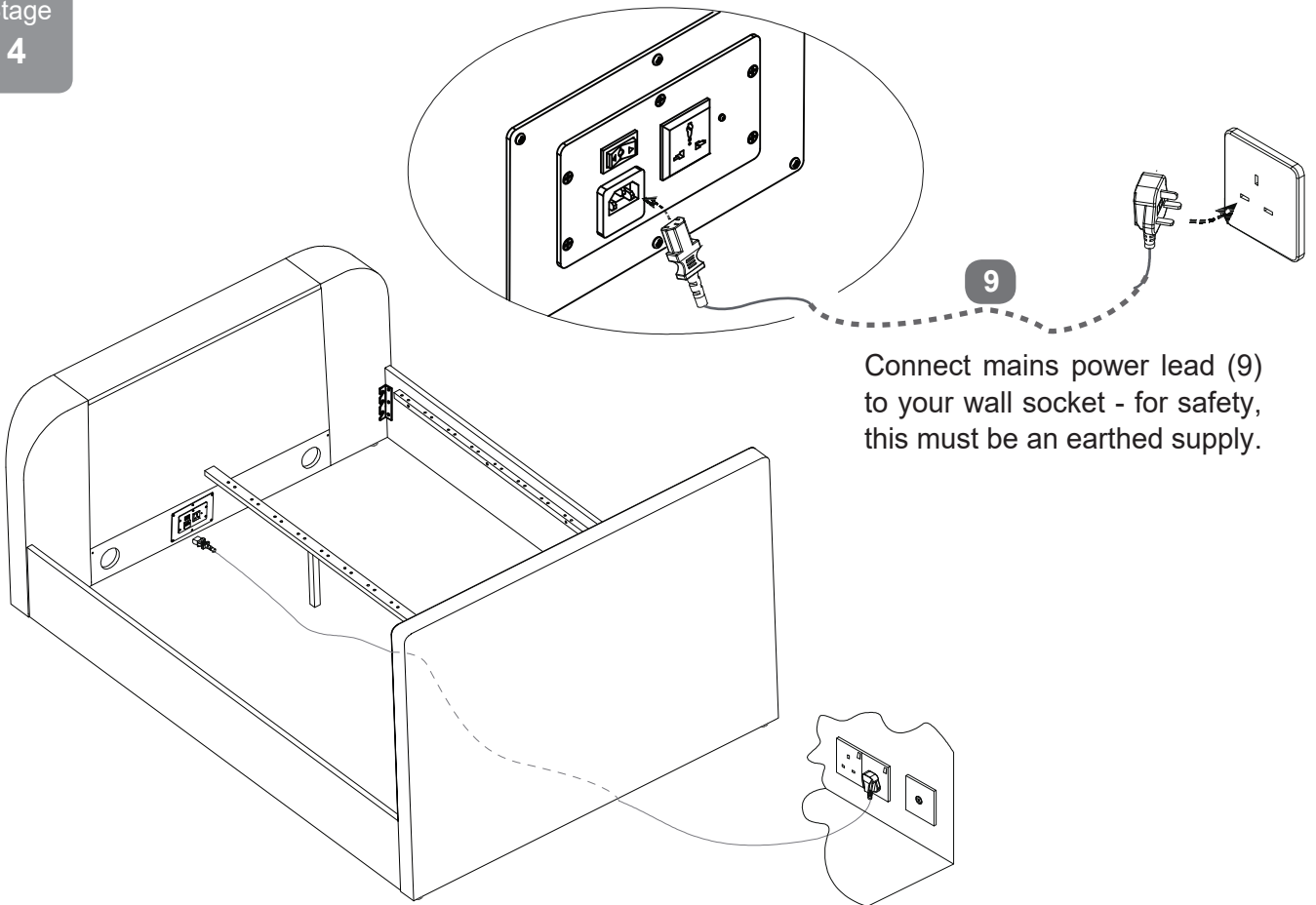

Stage

5

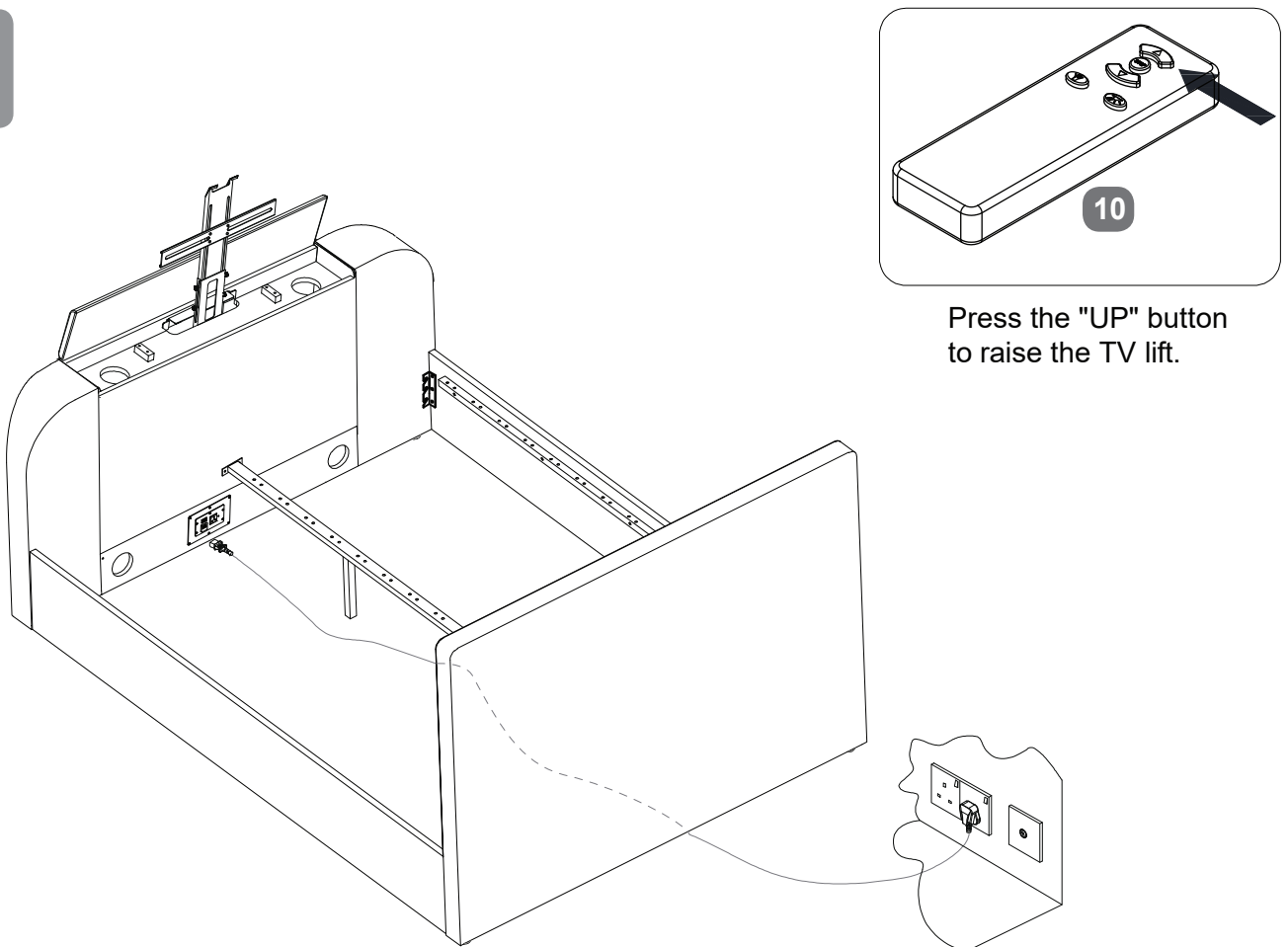

Note: For illustration purposes only, TV connections may vary.

TIP:
BEFORE FITTING THE TV,
PUSH CABLES THROUGH
EACH DUCT FROM THE TOP.
CHOOSE THE BEST SIDE TO
USE DEPENDING ON WHERE
THE CONNECTION PORTS
ARE ON BACK OF YOUR TV.
NEVER CROSS CABLES FROM
ONE SIDE TO THE OTHER.

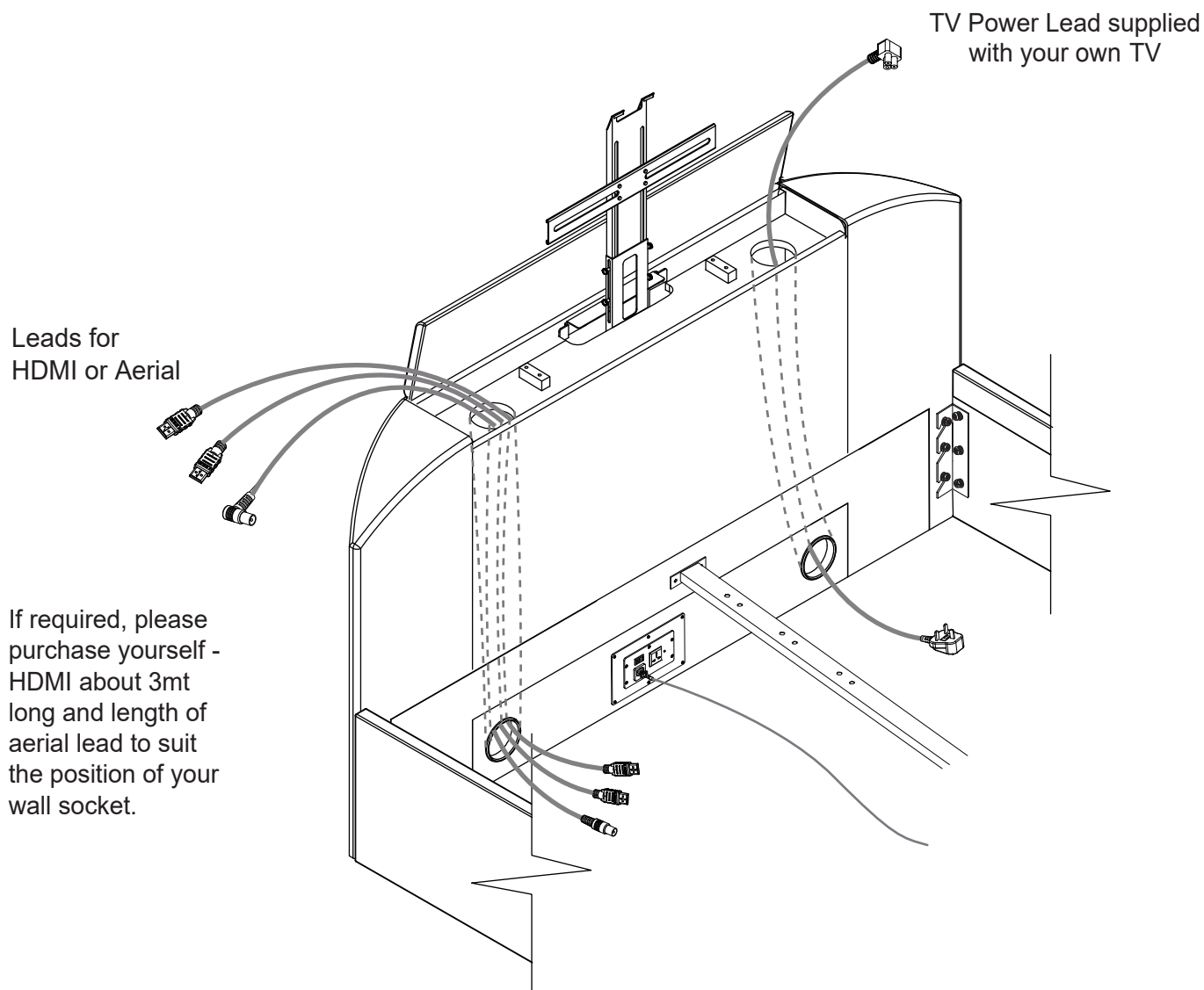

TV INSTALLATION

Stage
7

TV INSTALLATION KIT

- a Screw-Washer set (M8/M6/M4)  x2
- b Allen Key (5mm/4mm/2.5mm)  x1

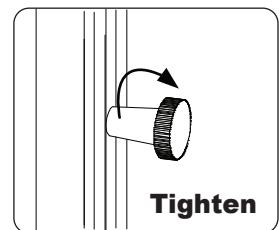
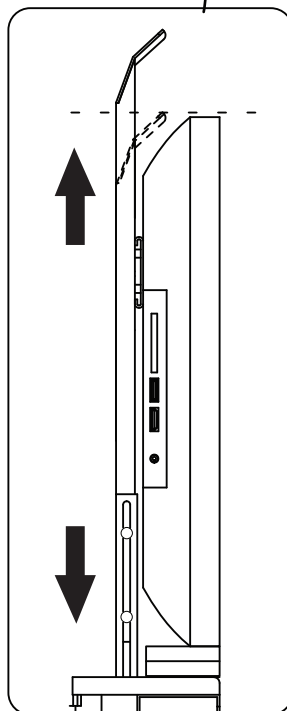
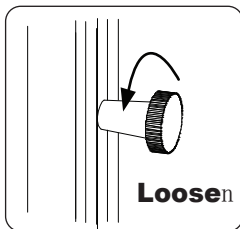
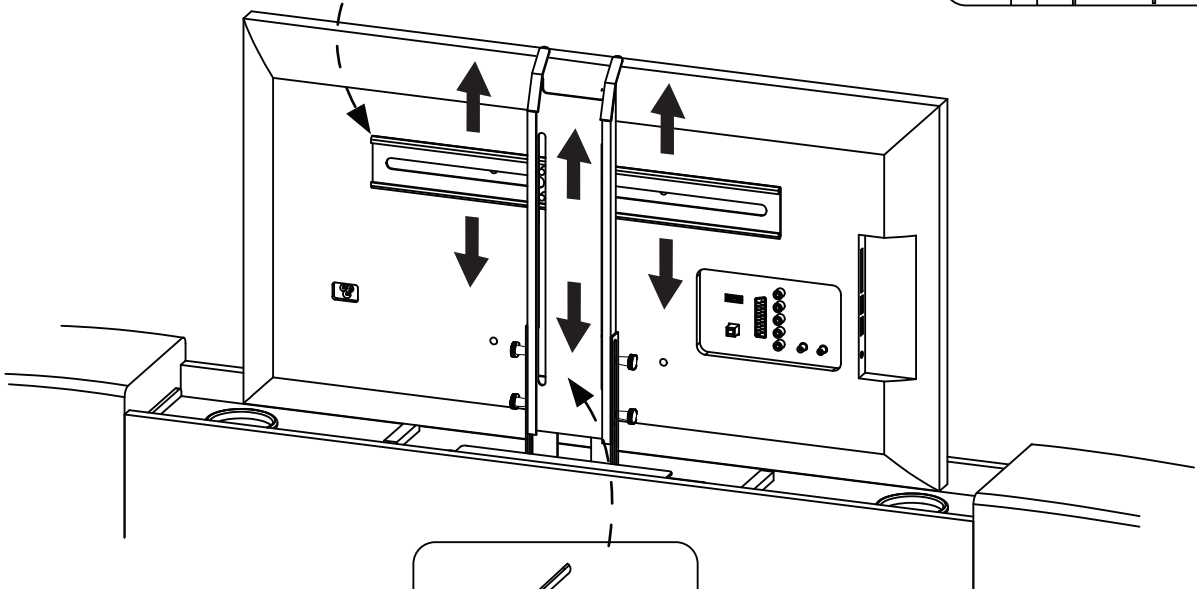
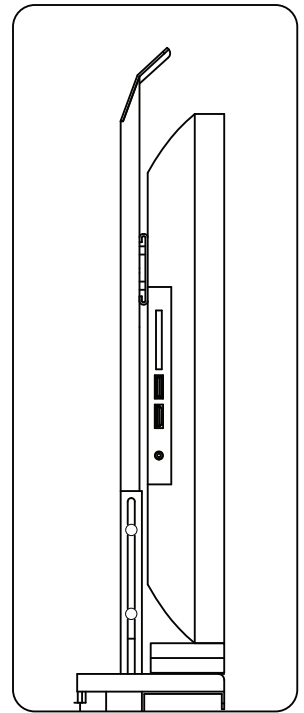
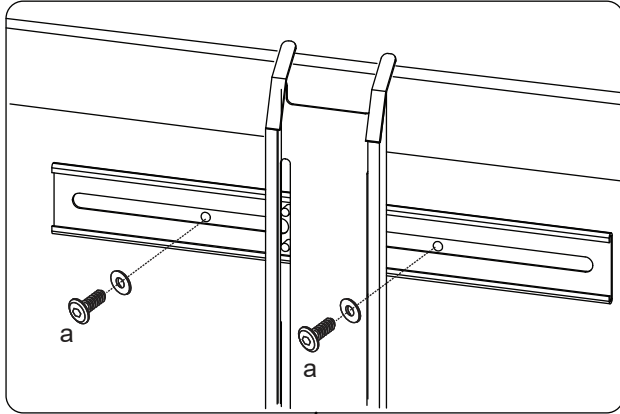

Note: For illustration purposes only, TV connections may vary.

TV power lead supplied
with your own TV

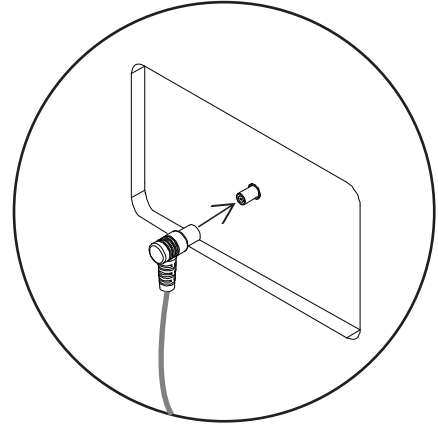
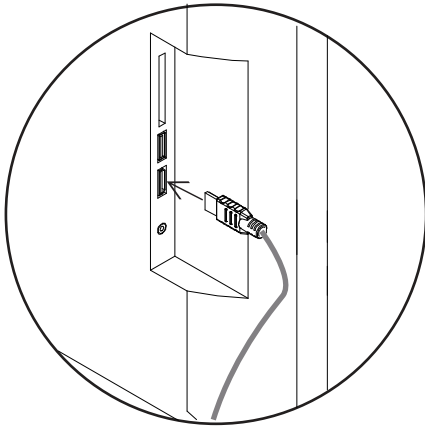
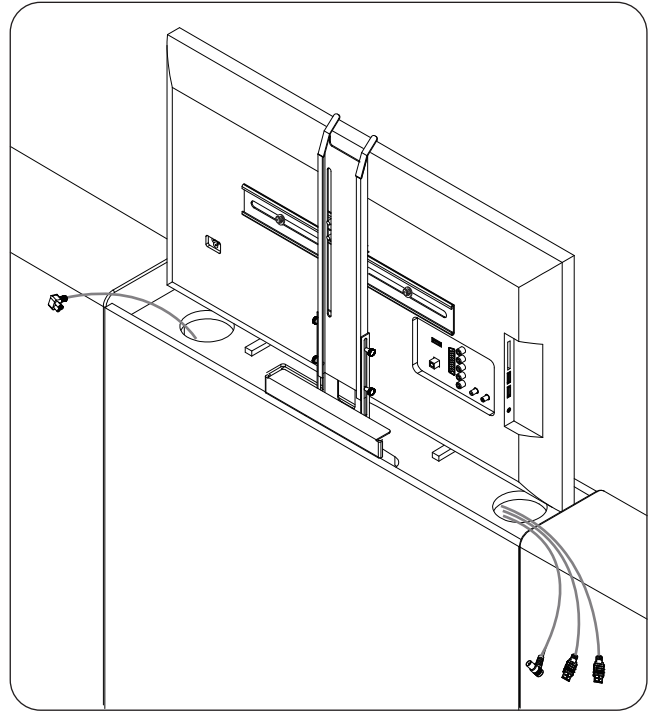
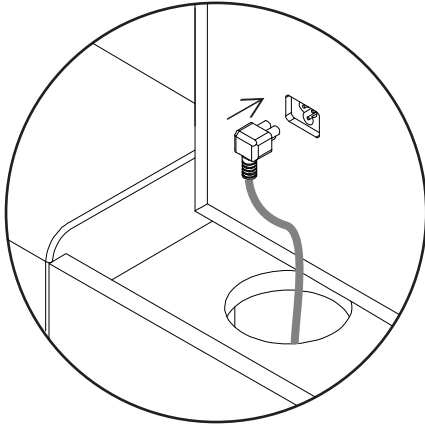

**PLUG IN - KEEP ALL CABLES TIGHT
- USE CLIPS & TIES PROVIDED.**

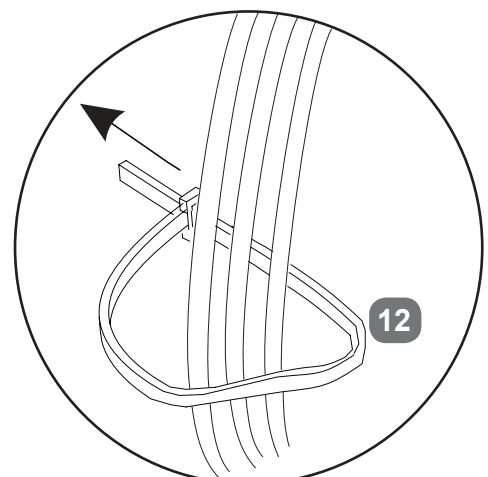
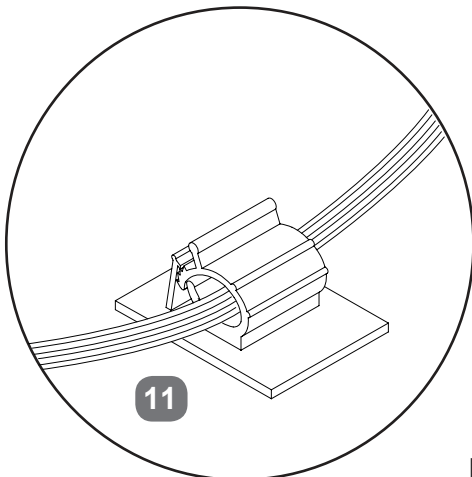

Keep wires tight - peel
off cover from cable clips
& adhere to back of TV.

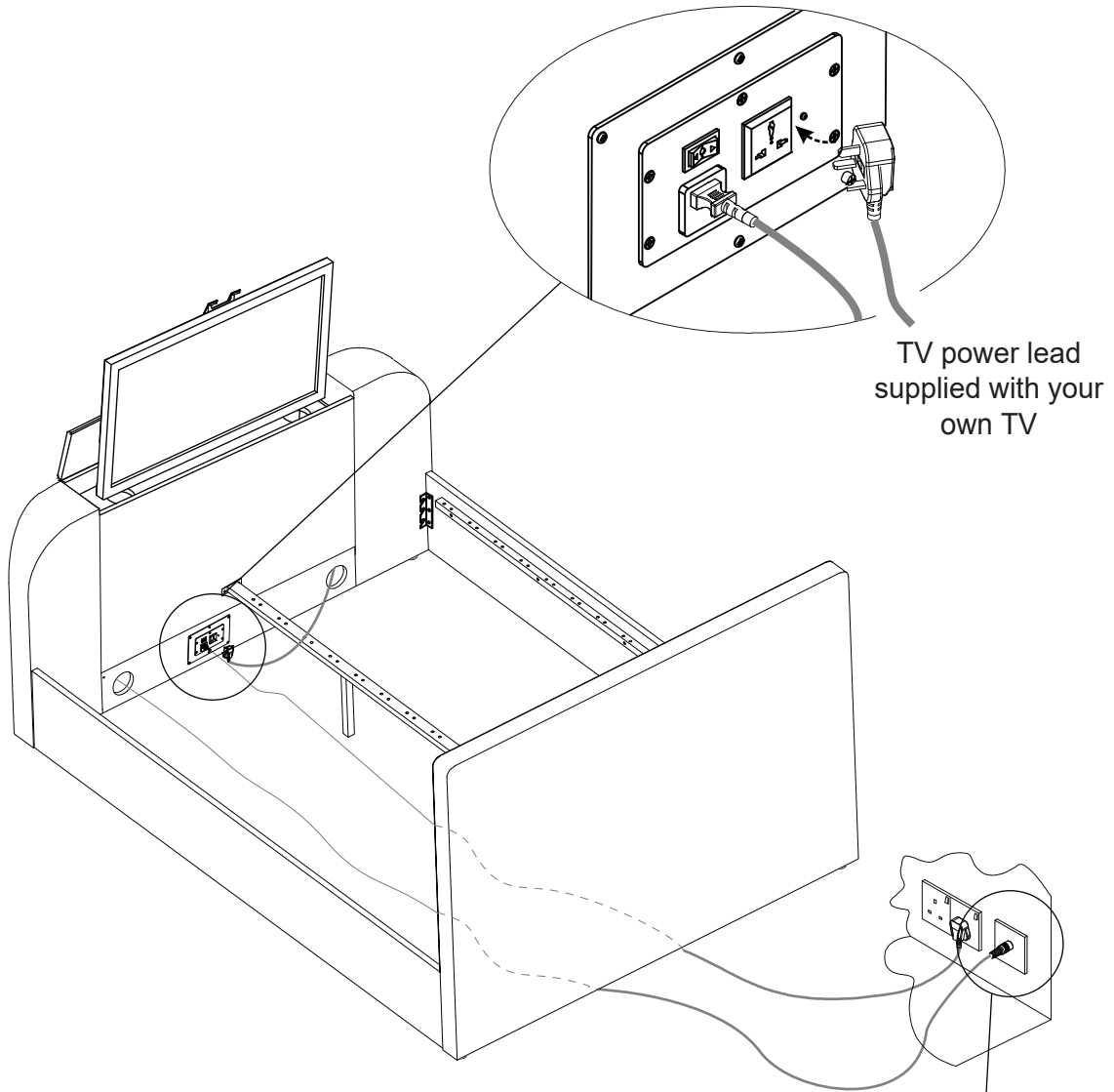

TV power lead
supplied with your
own TV

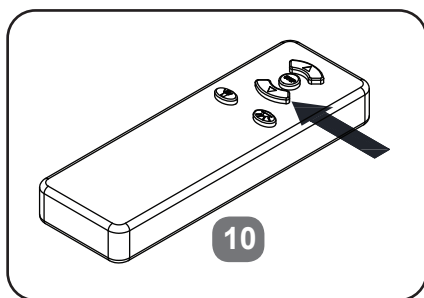

Press the "DOWN" button
to lower the TV lift.

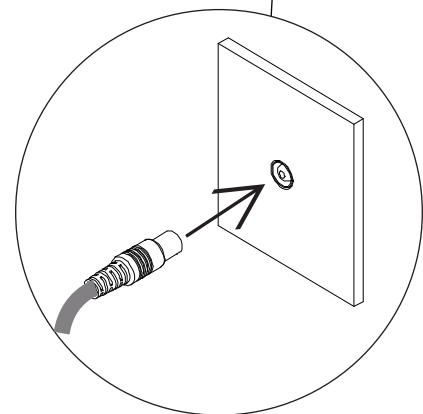

Aerial lead supplied
by yourself if required

Bed Assembly

Stage
10

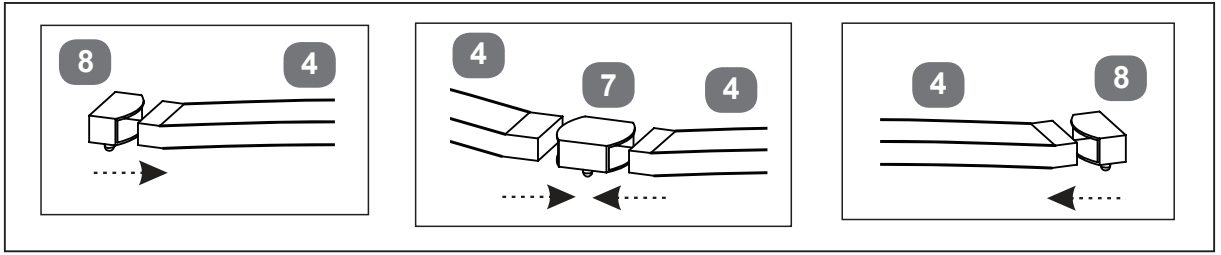

Double & King Size

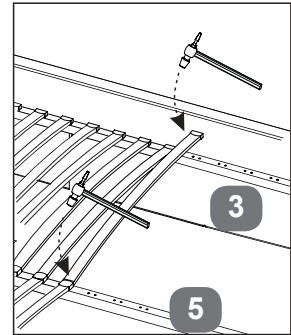
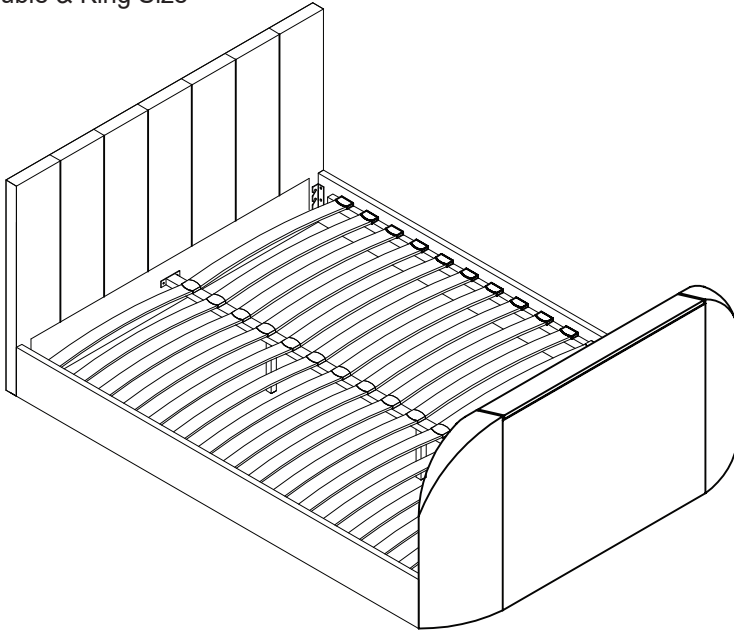

On either Double, King or Super King slat frames - fit the slats to the frame as follows:
Slide slats (4) into the double plastic caps (7).
Slide single plastic caps (8) onto each end.
Connect each set one by one onto the centre support bar(s) (5) & the metal support rail on each side rail (3) - align the lugs & tap gently with a light hammer.

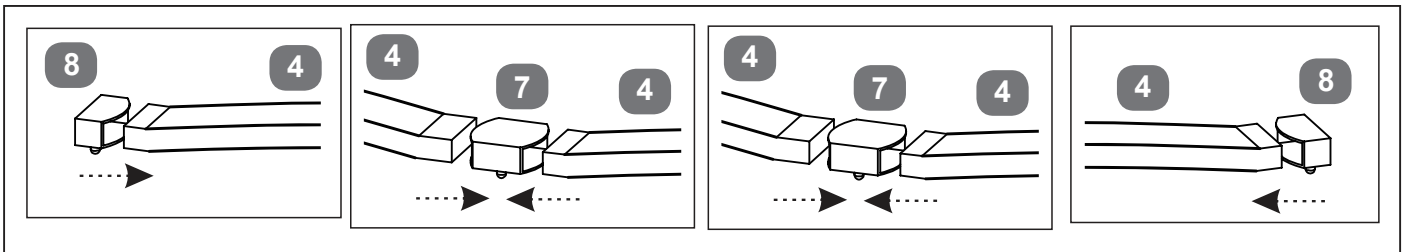

Super King Size

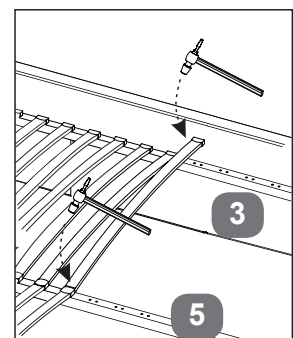
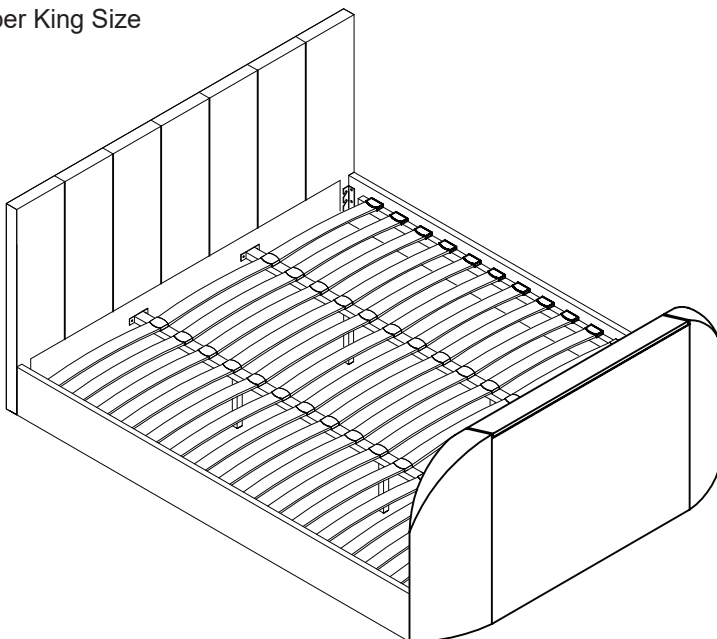

Technical Specifications

Overall Dimensions (LWH mm)

Double: 2200 x 1430 x 1155

King: 2300 x 1580 x 1155

Super King: 2300 x 1880 x 1155

Internal Dimensions (LW mm)

Double: 1920 x 1380

King: 2020 x 1530

Super King: 2020 x 1830

Distance Between Slats (mm)

Double: 75

King & Super King: 73

Slat Dimension (mm)

Double: 690 x 53 x 9

King: 765 x 53 x 9

Super King: 610 x 53 x 9

Maximum TV Dims (WHD mm)

975 x 575 x 85

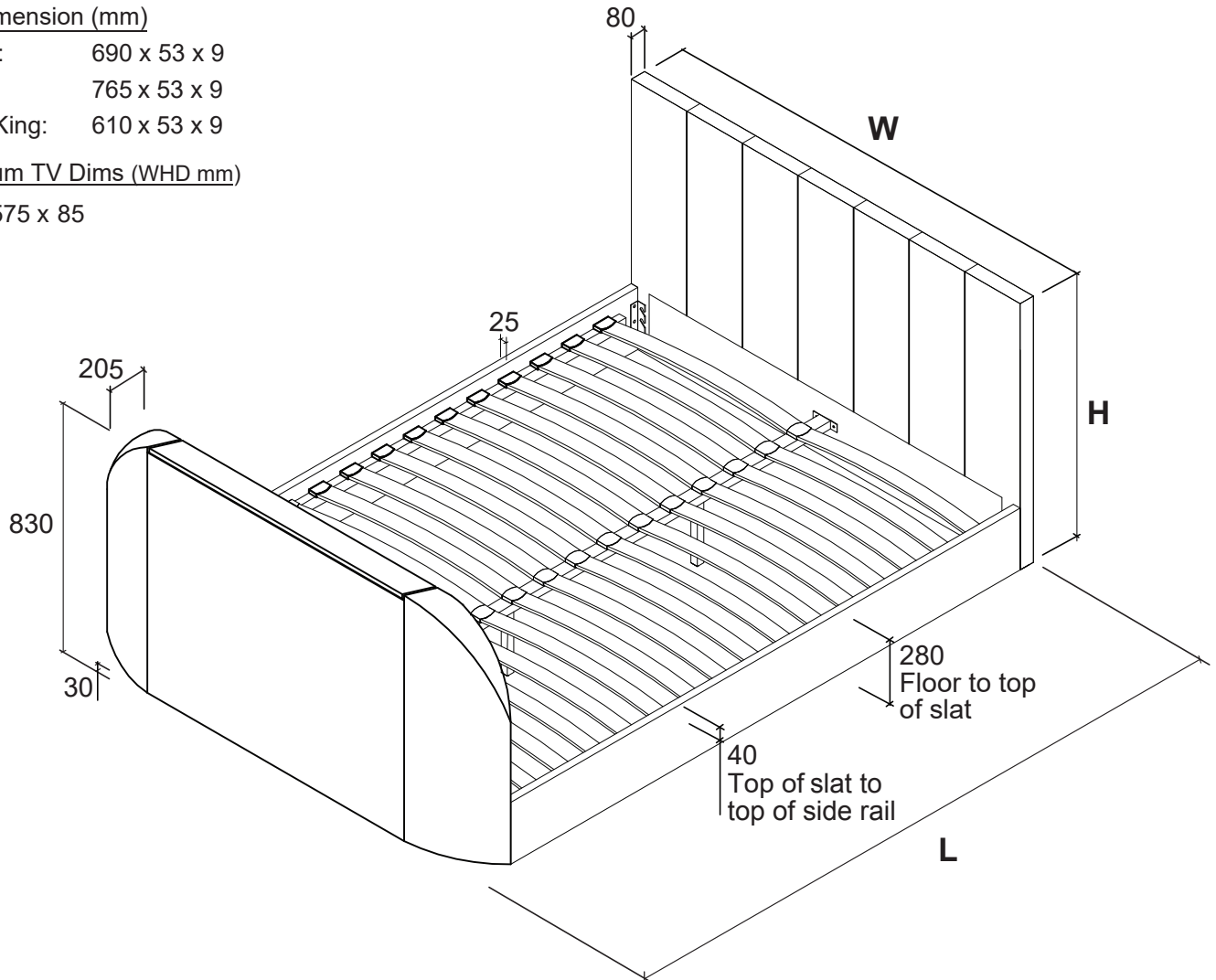

TV BED SAFETY INFORMATION

GENERAL INFORMATION

It is very important not to place any vessel containing liquids, e.g. drinks or vase of flowers on top of the TV footboard that may accidentally spill and enter the TV compartment as this could cause damage to the TV and/or the TV lifting equipment. If this happens turn off the power and contact your retailer.

Do not expose the bed to an undue level of heat - keep away from radiators.

Never allow anyone to sit on the foot end of the bed - keep children well away from moving parts.

To keep your bed clean, we recommend that it be wiped over with a slightly dampened cloth, or if fabric, use a light vacuum cleaner; disconnect power before cleaning.

Supplied with the bed is a remote control to operate the TV Lift and there will be one to operate the television itself. Both these remotes will be supplied with batteries - there are no batteries in the rest of the equipment.

When it is time to change the batteries there are strict controls for disposal of the old ones - your local council can advise on how to safely dispose of them. Never burn batteries on an open fire as they could explode.

IMPORTANT POWER INFORMATION

Before fixing the mattress baseboards to the bed, please follow the instructions below:

Plug in the main power supply lead supplied with your bed; this is packed inside the TV footend pack

It is essential that this power lead is connected to an earthed socket be it a wall socket or extension lead - otherwise there is risk of damage or even electric-shock.

The wall socket providing the power must be accessible at all times in case you need to switch off the electric supply.

Power cable supplied with this bed or other approved mains powered extension leads used to power your equipment must not be placed where they can be walked on - this is dangerous and could lead to accidents.

Power outlets, extension leads or adapters must not be overloaded beyond their limit - this can result in fire or electric shock.

During an electrical or lightening storm - disconnect the power completely as a precaution.

Always un-plug the power when going on holiday or when the bed is not used for an extended period.

If you have young children in the home always disconnect the power at the wall socket for extra safety.

Do not interfere with or modify any cables already fitted and do not add any media cables unless they are routed through the ducts as shown. All leads must be tightly connected to back of TV, never hanging loose where they can get trapped.

Never touch moving parts or any part of the equipment - if something needs to be checked, disconnect the power first.

Do not insert anything into the footboard as this could seriously damage the TV and/or the TV lifting equipment and could, if done carelessly, cause serious damage or injury.

If the equipment doesn't operate normally or if there is any unusual noises, disconnect the power and contact your retailer for advice.

TELEVISION INFORMATION

Please follow the assembly steps for initial operation of the TV Lift, your TV and any media cables required.

Push the television power plug (supplied with your own TV), into it's own special socket which is on the face of the footboard clearly shown in the instructions. For safety and to prevent overheating, this socket is only to be used for the television as it does not have a constant power supply.

Raise the TV Lift by pressing the UP button of the remote control.

If required you can connect media cables the television ports.

Please use the cable clips & cable ties to make certain there are no loose wires to snag or get trapped.

The television can now be operated following the TV User Guide.

When finished viewing, lower the television back into the footboard by pressing the DOWN button of the remote control.

For safety and to stop any overheating, power to the television is switched off when lift reaches the bottom rest position.

When the UP button is pressed - the TV Lifting Column rises and power is turned back on automatically.

TROUBLE SHOOTING

- If your equipment does not operate please check all the electrical connections to the wall socket and check that electricity is reaching the main power input plug bringing power to the footboard.
- Make sure that the TV is switched on - but note that the television will only work when it is in the up position.
- Check that the remote control has not lost its connection with the TV Lift - please see pairing instructions on Page (2).

IMPORTANT: Care should be taken when connecting electrical items. If you are in any doubt about the connections please consult an approved electrician. If you still have a problem please contact your retailer for advice.